

穴あけ用

シグマドリル・ハード

DZ-DHS / DV-DHS形

1. 本体剛性が高い
2. 耐折損性と耐チップング性が高い
3. 耐熱、耐摩耗性が高い
4. 欠損性を大幅に改善

- 70HRCの高硬度材の加工が可能な高硬度材専用ドリル
- 有効加工深さ5×Dc
- ねじれ角15°

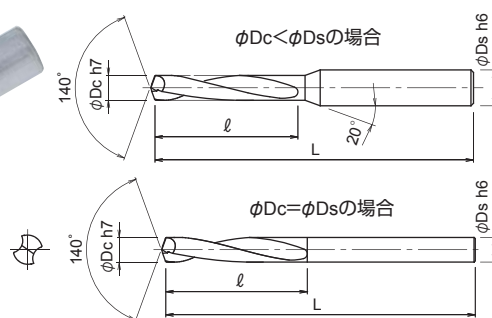

φ12を越え

形番	在庫	寸法 (mm)			
		φDc	ℓ	L	φDs
DZ-DHS0200-12	●	2.0	12	55	3
DZ-DHS0200	●	2.0	16	55	3
DZ-DHS0200-21	●	2.0	21	55	3
DZ-DHS0205	□	2.05	16	55	3
DZ-DHS0210	●	2.1	16	55	3
DZ-DHS0215	□	2.15	16	55	3
DZ-DHS0220	●	2.2	16	55	3
DZ-DHS0225	□	2.25	16	55	3
DZ-DHS0230	●	2.3	16	55	3
DZ-DHS0235	□	2.35	16	55	3
DZ-DHS0240	●	2.4	16	55	3
DZ-DHS0245	□	2.45	16	55	3
DZ-DHS0250	●	2.5	16	55	3
DZ-DHS0255	□	2.55	16	55	3
DZ-DHS0250-21	●	2.5	21	55	3
DZ-DHS0260	●	2.6	16	55	3
DZ-DHS0265	□	2.65	16	55	3
DZ-DHS0270	●	2.7	16	55	3
DZ-DHS0275	□	2.75	16	55	3
DZ-DHS0280	●	2.8	16	55	3
DZ-DHS0285	□	2.85	16	55	3
DZ-DHS0290	●	2.9	16	55	3
DZ-DHS0295	□	2.95	21	60	4
DZ-DHS0300	●	3	21	60	4
DZ-DHS0305	□	3.05	24	60	4
DZ-DHS0310	□	3.1	24	60	4
DZ-DHS0315	□	3.15	24	60	4
DZ-DHS0320	□	3.2	24	60	4
DZ-DHS0325	□	3.25	24	60	4
DZ-DHS0330	●	3.3	24	60	4
DZ-DHS0335	□	3.35	24	60	4
DZ-DHS0340	●	3.4	24	60	4
DZ-DHS0345	□	3.45	24	60	4

形番	在庫	寸法 (mm)			
		φDc	ℓ	L	φDs
DZ-DHS0350	●	3.5	24	60	4
DZ-DHS0355	□	3.55	27	60	4
DZ-DHS0360	□	3.6	27	60	4
DZ-DHS0365	□	3.65	27	60	4
DZ-DHS0370	□	3.7	27	60	4
DZ-DHS0375	□	3.75	27	60	4
DZ-DHS0380	●	3.8	27	60	4
DZ-DHS0385	□	3.85	27	60	4
DZ-DHS0390	□	3.9	27	60	4
DZ-DHS0395	□	3.95	27	60	4
DZ-DHS0400	●	4	27	60	4
DZ-DHS0405	□	4.05	29	63	6
DZ-DHS0410	□	4.1	29	63	6
DZ-DHS0415	□	4.15	29	63	6
DZ-DHS0420	●	4.2	29	63	6
DZ-DHS0425	□	4.25	29	63	6
DZ-DHS0430	●	4.3	29	63	6
DZ-DHS0435	□	4.35	29	63	6
DZ-DHS0440	●	4.4	29	63	6
DZ-DHS0445	□	4.45	29	63	6
DZ-DHS0450	●	4.5	29	63	6
DZ-DHS0455	□	4.55	32	68	6
DZ-DHS0460	□	4.6	32	68	6
DZ-DHS0465	□	4.65	32	68	6
DZ-DHS0470	□	4.7	32	68	6
DZ-DHS0475	□	4.75	32	68	6
DZ-DHS0480	□	4.8	32	68	6
DZ-DHS0485	□	4.85	32	68	6
DZ-DHS0490	□	4.9	32	68	6
DZ-DHS0495	□	4.95	32	68	6
DZ-DHS0500	●	5	32	68	6
DZ-DHS0505	□	5.05	34	72	6
DZ-DHS0510	●	5.1	34	72	6

注) 標準切削条件はP.724~725をご参照ください。

6145

●: メーカー在庫 □: 流通在庫 ☆: 海外在庫 ○: 近日在庫 ○: 在庫なくなり次第廃番 ※: 受注生産品

穴あけ用

シグマドリル・ハード

DZ-DHS / DV-DHS形

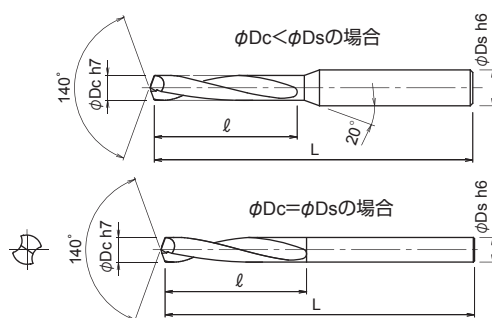

(前ページの続き)

形番	在庫	寸法 (mm)			
		ϕD_c	ℓ	L	ϕD_s
DZ-DHS0515	□	5.15	34	72	6
DZ-DHS0520	●	5.2	34	72	6
DZ-DHS0525	□	5.25	34	72	6
DZ-DHS0530	□	5.3	34	72	6
DZ-DHS0535	□	5.35	34	72	6
DZ-DHS0540	□	5.4	34	72	6
DZ-DHS0545	□	5.45	34	72	6
DZ-DHS0550	□	5.5	34	72	6
DZ-DHS0555	□	5.55	36	74	6
DZ-DHS0560	□	5.6	36	74	6
DZ-DHS0565	□	5.65	36	74	6
DZ-DHS0570	□	5.7	36	74	6
DZ-DHS0575	□	5.75	36	74	6
DZ-DHS0580	□	5.8	36	74	6
DZ-DHS0585	□	5.85	36	74	6
DZ-DHS0590	□	5.9	36	74	6
DZ-DHS0595	□	5.95	41	81	6
DZ-DHS0600	●	6	41	81	6
DZ-DHS0605	□	6.05	41	81	8
DZ-DHS0610	□	6.1	41	81	8
DZ-DHS0615	□	6.15	41	81	8
DZ-DHS0620	□	6.2	41	81	8
DZ-DHS0625	□	6.25	41	81	8
DZ-DHS0630	□	6.3	41	81	8
DZ-DHS0635	□	6.35	41	81	8
DZ-DHS0640	□	6.4	41	81	8
DZ-DHS0645	□	6.45	41	81	8
DZ-DHS0650	□	6.5	41	81	8
DZ-DHS0655	□	6.55	43	83	8
DZ-DHS0660	□	6.6	43	83	8
DZ-DHS0665	□	6.65	43	83	8
DZ-DHS0670	□	6.7	43	83	8
DZ-DHS0675	□	6.75	43	83	8

形番	在庫	寸法 (mm)			
		ϕD_c	ℓ	L	ϕD_s
DZ-DHS0680	●	6.8	43	83	8
DZ-DHS0685	□	6.85	43	83	8
DZ-DHS0690	●	6.9	43	83	8
DZ-DHS0695	□	6.95	43	83	8
DZ-DHS0700	●	7	43	83	8
DZ-DHS0705	□	7.05	45	87	8
DZ-DHS0710	□	7.1	45	87	8
DZ-DHS0715	□	7.15	45	87	8
DZ-DHS0720	□	7.2	45	87	8
DZ-DHS0725	□	7.25	45	87	8
DZ-DHS0730	□	7.3	45	87	8
DZ-DHS0735	□	7.35	45	87	8
DZ-DHS0740	□	7.4	45	87	8
DZ-DHS0745	□	7.45	45	87	8
DZ-DHS0750	□	7.5	45	87	8
DZ-DHS0755	□	7.55	48	90	8
DZ-DHS0760	□	7.6	48	90	8
DZ-DHS0765	□	7.65	48	90	8
DZ-DHS0770	□	7.7	48	90	8
DZ-DHS0775	□	7.75	48	90	8
DZ-DHS0780	□	7.8	48	90	8
DZ-DHS0785	□	7.85	48	90	8
DZ-DHS0790	□	7.9	48	90	8
DZ-DHS0795	□	7.95	48	90	8
DZ-DHS0800	●	8	48	90	8
DZ-DHS0805	□	8.05	53	96	10
DZ-DHS0810	□	8.1	53	96	10
DZ-DHS0815	□	8.15	53	96	10
DZ-DHS0820	□	8.2	53	96	10
DZ-DHS0825	□	8.25	53	96	10
DZ-DHS0830	□	8.3	53	96	10
DZ-DHS0835	□	8.35	53	96	10
DZ-DHS0840	□	8.4	53	96	10

注) 標準切削条件はP.724~725をご参照ください。

6145

穴あけ用

シグマドリル・ハード

DZ-DHS / DV-DHS形

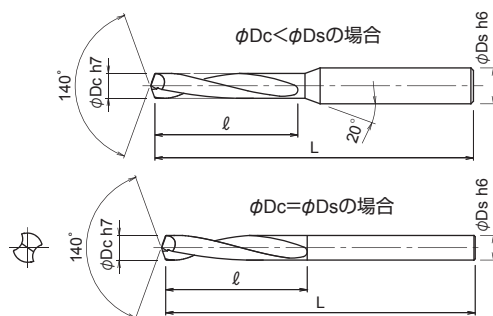

(前ページの続き)

形番	在庫	寸法 (mm)			
		ϕD_c	ℓ	L	ϕD_s
DZ-DHS0845	□	8.45	53	96	10
DZ-DHS0850	●	8.5	53	96	10
DZ-DHS0855	□	8.55	55	98	10
DZ-DHS0860	●	8.6	55	98	10
DZ-DHS0865	□	8.65	55	98	10
DZ-DHS0870	□	8.7	55	98	10
DZ-DHS0875	□	8.75	55	98	10
DZ-DHS0880	□	8.8	55	98	10
DZ-DHS0885	□	8.85	55	98	10
DZ-DHS0890	□	8.9	55	98	10
DZ-DHS0895	□	8.95	55	98	10
DZ-DHS0900	●	9	55	98	10
DZ-DHS0905	□	9.05	58	102	10
DZ-DHS0910	□	9.1	58	102	10
DZ-DHS0915	□	9.15	58	102	10
DZ-DHS0920	□	9.2	58	102	10
DZ-DHS0925	□	9.25	58	102	10
DZ-DHS0930	□	9.3	58	102	10
DZ-DHS0935	□	9.35	58	102	10
DZ-DHS0940	□	9.4	58	102	10
DZ-DHS0945	□	9.45	58	102	10
DZ-DHS0950	□	9.5	58	102	10
DZ-DHS0955	□	9.55	60	105	10
DZ-DHS0960	□	9.6	60	105	10
DZ-DHS0965	□	9.65	60	105	10
DZ-DHS0970	□	9.7	60	105	10
DZ-DHS0975	□	9.75	60	105	10
DZ-DHS0980	□	9.8	60	105	10
DZ-DHS0985	□	9.85	60	105	10
DZ-DHS0990	□	9.9	60	105	10
DZ-DHS0995	□	9.95	60	105	10
DZ-DHS1000	●	10	60	105	10
DZ-DHS1005	□	10.05	66	112	12

形番	在庫	寸法 (mm)			
		ϕD_c	ℓ	L	ϕD_s
DZ-DHS1010	□	10.1	66	112	12
DZ-DHS1015	□	10.15	66	112	12
DZ-DHS1020	□	10.2	66	112	12
DZ-DHS1025	□	10.25	66	112	12
DZ-DHS1030	●	10.3	66	112	12
DZ-DHS1035	□	10.35	66	112	12
DZ-DHS1040	●	10.4	66	112	12
DZ-DHS1045	□	10.45	66	112	12
DZ-DHS1050	□	10.5	66	112	12
DZ-DHS1055	□	10.55	68	114	12
DZ-DHS1060	□	10.6	68	114	12
DZ-DHS1065	□	10.65	68	114	12
DZ-DHS1070	□	10.7	68	114	12
DZ-DHS1075	□	10.75	68	114	12
DZ-DHS1080	□	10.8	68	114	12
DZ-DHS1085	□	10.85	68	114	12
DZ-DHS1090	□	10.9	68	114	12
DZ-DHS1095	□	10.95	68	114	12
DZ-DHS1100	●	11	68	114	12
DZ-DHS1105	□	11.05	71	118	12
DZ-DHS1110	□	11.1	71	118	12
DZ-DHS1120	□	11.2	71	118	12
DZ-DHS1130	□	11.3	71	118	12
DZ-DHS1140	□	11.4	71	118	12
DZ-DHS1150	□	11.5	71	118	12
DZ-DHS1160	□	11.6	73	121	12
DZ-DHS1170	□	11.7	73	121	12
DZ-DHS1180	□	11.8	73	121	12
DZ-DHS1190	□	11.9	73	121	12
DZ-DHS1200	●	12	73	121	12
DZ-DHS1210	□	12.1	74	125	14
DZ-DHS1220	□	12.2	74	125	14
DV-DHS1250	□	12.5	74	125	14

注) 標準切削条件はP.724~725をご参照ください。

●: メーカー在庫 □: 流通在庫 ☆: 海外在庫 ○: 近日在庫 ○: 在庫なくなり次第廃番 ※: 受注生産品