



ドリル径
ø5.0~16.0 mm

IT9~10
精度目安



0°
ねじれ角

5/8
L/D

135°
先端角

鑄鉄・アルミ用高速深穴加工
ノンコーティングソリッドドリル

内部給油



ドリル径 øDc	5.0<øDc≤6.0	6.0<øDc≤16.0
許容差	+0.020 +0.010	+0.025 +0.015

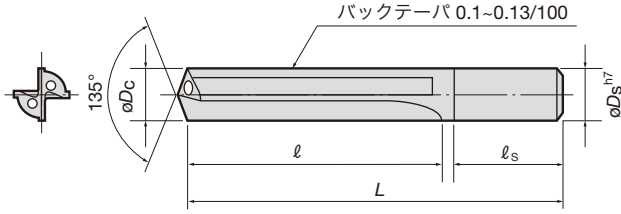

L/D = 5 (Sタイプ)

ドリル径 øDc	許容差	形番	在庫	寸法 (mm)			
				øDs	l	ls	L
5.0	+0.020 +0.010	FDC0500S	◇	5.0	40	38	80
5.1		FDC0510S	◇	6.0	44	40	85
5.2		FDC0520S	◇				
5.3		FDC0530S	◇				
5.4		FDC0540S	◇				
5.5		FDC0550S	◇				
5.6		FDC0560S	◇				
5.7		FDC0570S	◇				
5.8		FDC0580S	◇				
5.9		FDC0590S	◇				
6.0	FDC0600S	◇					
6.1	+0.025 +0.015	FDC0610S	◇	7.0	52	40	95
6.2		FDC0620S	◇				
6.3		FDC0630S	◇				
6.4		FDC0640S	◇				
6.5		FDC0650S	◇				
6.6		FDC0660S	◇				
6.7		FDC0670S	◇				
6.8		FDC0680S	◇				
6.9		FDC0690S	◇				
7.0		FDC0700S	◇				
7.1	+0.025 +0.015	FDC0710S	◇	8.0	60	42	105
7.2		FDC0720S	◇				
7.3		FDC0730S	◇				
7.4		FDC0740S	◇				
7.5		FDC0750S	◇				
7.6		FDC0760S	◇				
7.7		FDC0770S	◇				
7.8		FDC0780S	◇				
7.9		FDC0790S	◇				
8.0		FDC0800S	◇				
8.1	+0.025 +0.015	FDC0810S	◇	9.0	68	44	115
8.2		FDC0820S	◇				
8.3		FDC0830S	◇				
8.4		FDC0840S	◇				
8.5		FDC0850S	◇				
8.6		FDC0860S	◇				
8.7		FDC0870S	◇				
8.8		FDC0880S	◇				
8.9		FDC0890S	◇				
9.0		FDC0900S	◇				
9.1	+0.025 +0.015	FDC0910S	◇	10.0	76	44	125
9.2		FDC0920S	◇				
9.3		FDC0930S	◇				
9.4		FDC0940S	◇				

ドリル径 øDc	許容差	形番	在庫	寸法 (mm)							
				øDs	l	ls	L				
9.4	+0.025 +0.015	FDC0940S	◇	10.0	76	44	125				
9.5		FDC0950S	◇								
9.6		FDC0960S	◇								
9.7		FDC0970S	◇								
9.8		FDC0980S	◇								
9.9		FDC0990S	◇								
10.0		FDC1000S	◇								
10.5		FDC1050S	●					11.0	84	46	140
11.0		FDC1100S	●								
11.5		FDC1150S	●					12.0	92	48	150
12.0	FDC1200S	●									
12.5	FDC1250S	●	13.0	100	50	160					
13.0	FDC1300S	●									
13.5	FDC1350S	●	14.0	108	52	170					
14.0	FDC1400S	●									
14.5	FDC1450S	●	15.0	116	54	180					
15.0	FDC1500S	●									
15.5	FDC1550S	●	16.0	124	56	190					
16.0	FDC1600S	●									

L/D = (加工穴深さ)/(加工径)

製品在庫 ●: 在庫形番
◇: 当商品は専門店在庫です

11 穴あけ工具