

アルマックスモジュラーヘッド M-AMX3M / M-AMX3B

側面加工用

座繰り加工用

右刃右ネジレ30°

大型アルミ部品の加工に最適!

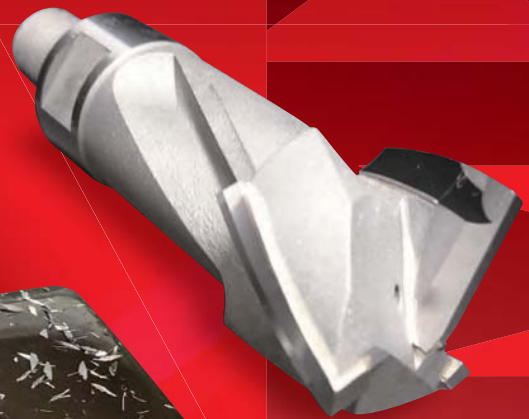

M-AMX3は、アルミ加工用3枚刃エンドミルです。
モジュラー（ヘッド交換式）で、切刃鏡面仕上げのシャープなエッジで鋭い切れ味、
オイルホール仕様で、切屑の排出性に優れています。
M(Milling)、B(Boring) 2タイプに、シャープエッジ・R0.2仕様を設定。
幅広いアルミ切削加工に対応致します。

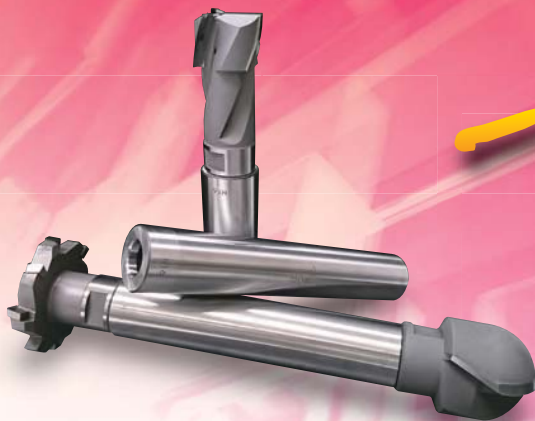

一刀両頭!!

オリジナルM20専用鋼シャンクホルダー M-SH。
1本でM16とM20に対応する
両頭鋼シャンクホルダー M-DSHもラインナップ。
シャンクホルダーの本数が嵩張る問題も解消出来ます。



株式会社 ヤマト

〒587-0011大阪府堺市美原区丹上530-1
TEL (072)361-4545(代) FAX (072)361-3678

M-AMX3M

- モジュラーヘッド (Milling)
- アルマックス エンドミル (アルミ・非鉄金属用)
- 油穴仕様 (4ヶ所) (底刃中心 1 + 3 外周側)
- 切刃鏡面仕上

側面、溝加工用

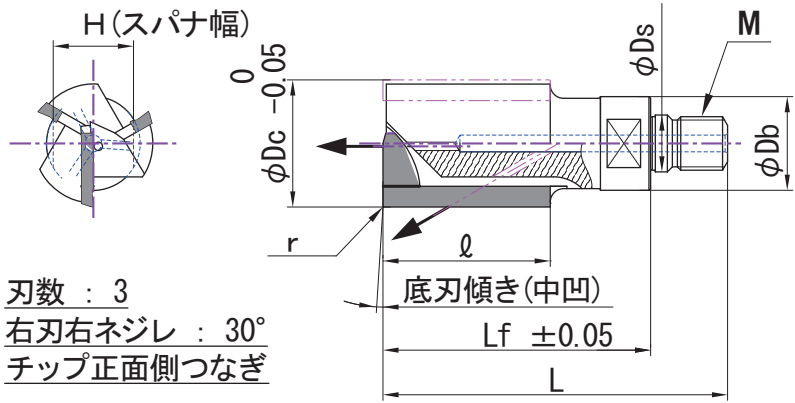

テープ材質 : K10 (超硬)

型番	在庫	寸法 (mm)								
		r	φDc	ℓ	Lf	L	φDs	φDb	H	M
M-AMX3M-25	●	0	25	40	70	91	12.5	23	19	M12
M-AMX3M-25xR0.2	●	0.2								
M-AMX3M-26	●	0								
M-AMX3M-26xR0.2	●	0.2								
M-AMX3M-27	●	0								
M-AMX3M-27xR0.2	●	0.2								
M-AMX3M-28	●	0								
M-AMX3M-28xR0.2	●	0.2								
M-AMX3M-29	●	0	29	50	80	103	17	28	24	M16
M-AMX3M-29xR0.2	●	0.2								
M-AMX3M-30	●	0								
M-AMX3M-30xR0.2	●	0.2								
M-AMX3M-31	●	0								
M-AMX3M-31xR0.2	●	0.2								
M-AMX3M-32	●	0								
M-AMX3M-32xR0.2	●	0.2								
M-AMX3M-33	●	0								
M-AMX3M-33xR0.2	●	0.2								
M-AMX3M-34	●	0								
M-AMX3M-34xR0.2	●	0.2								
M-AMX3M-35	●	0								
M-AMX3M-35xR0.2	●	0.2								
M-AMX3M-36	●	0								
M-AMX3M-36xR0.2	●	0.2								
M-AMX3M-37	●	0								
M-AMX3M-37xR0.2	●	0.2								
M-AMX3M-38	●	0								
M-AMX3M-38xR0.2	●	0.2								
M-AMX3M-39	●	0								
M-AMX3M-39xR0.2	●	0.2								
M-AMX3M-40	●	0								
M-AMX3M-40xR0.2	●	0.2								
M-AMX3M-41	△	0	41	50	85	115	21	35	30	M20
M-AMX3M-41xR0.2	△	0.2								
M-AMX3M-42	●	0								
M-AMX3M-42xR0.2	●	0.2								
M-AMX3M-43	△	0								
M-AMX3M-43xR0.2	△	0.2								
M-AMX3M-44	△	0								
M-AMX3M-44xR0.2	△	0.2								
M-AMX3M-45	●	0								
M-AMX3M-45xR0.2	●	0.2								
M-AMX3M-46	△	0								
M-AMX3M-46xR0.2	△	0.2								
M-AMX3M-47	△	0								
M-AMX3M-47xR0.2	△	0.2								
M-AMX3M-48	△	0								
M-AMX3M-48xR0.2	△	0.2								
M-AMX3M-49	△	0								
M-AMX3M-49xR0.2	△	0.2								
M-AMX3M-50	●	0								
M-AMX3M-50xR0.2	●	0.2								

●印は標準在庫品

△印は受注製作品

M-AMX3B

- モジュラーヘッド (Boring)
- アルマックス ボーリングカッタ (アルミ・非鉄金属用)
- 油穴仕様 (4ヶ所) (底刃中心 1 + 3 外周側)
- 切刃鏡面仕上

突込み、座繰り加工用

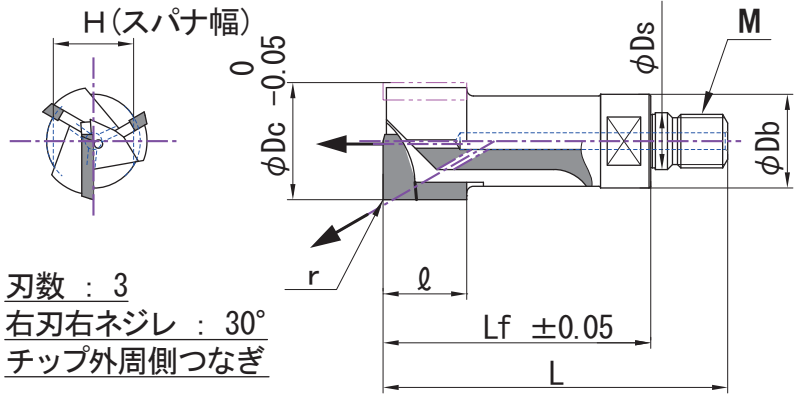

テープ材質：K10 (超硬)

型番	在庫	寸法 (mm)								
		r	φDc	ℓ	Lf	L	φDs	φDb	H	M
M-AMX3B-25	●	0	25	25	70	91	12.5	23	19	M12
M-AMX3B-25xR0.2	●	0.2								
M-AMX3B-26	●	0								
M-AMX3B-26xR0.2	●	0.2								
M-AMX3B-27	●	0								
M-AMX3B-27xR0.2	●	0.2								
M-AMX3B-28	●	0	28							
M-AMX3B-28xR0.2	●	0.2								
M-AMX3B-29	●	0	29							
M-AMX3B-29xR0.2	●	0.2								
M-AMX3B-30	●	0	30							
M-AMX3B-30xR0.2	●	0.2								
M-AMX3B-31	●	0	31							
M-AMX3B-31xR0.2	●	0.2								
M-AMX3B-32	●	0	32							
M-AMX3B-32xR0.2	●	0.2								
M-AMX3B-33	●	0	33							
M-AMX3B-33xR0.2	●	0.2								
M-AMX3B-34	●	0	34							
M-AMX3B-34xR0.2	●	0.2								
M-AMX3B-35	●	0	35							
M-AMX3B-35xR0.2	●	0.2								
M-AMX3B-36	●	0	36							
M-AMX3B-36xR0.2	●	0.2								
M-AMX3B-37	●	0	37							
M-AMX3B-37xR0.2	●	0.2								
M-AMX3B-38	●	0	38							
M-AMX3B-38xR0.2	●	0.2								
M-AMX3B-39	●	0	39							
M-AMX3B-39xR0.2	●	0.2								
M-AMX3B-40	●	0	40							
M-AMX3B-40xR0.2	●	0.2								
M-AMX3B-41	△	0	41							
M-AMX3B-41xR0.2	△	0.2								
M-AMX3B-42	●	0	42							
M-AMX3B-42xR0.2	●	0.2								
M-AMX3B-43	△	0	43							
M-AMX3B-43xR0.2	△	0.2								
M-AMX3B-44	△	0	44							
M-AMX3B-44xR0.2	△	0.2								
M-AMX3B-45	●	0	45							
M-AMX3B-45xR0.2	●	0.2								
M-AMX3B-46	△	0	46							
M-AMX3B-46xR0.2	△	0.2								
M-AMX3B-47	△	0	47							
M-AMX3B-47xR0.2	△	0.2								
M-AMX3B-48	△	0	48							
M-AMX3B-48xR0.2	△	0.2								
M-AMX3B-49	△	0	49							
M-AMX3B-49xR0.2	△	0.2								
M-AMX3B-50	●	0	50							
M-AMX3B-50xR0.2	●	0.2								

●印は標準在庫品

△印は受注製作品

モジュラーヘッド取付専用ホルダー

M-DSH

Duplex Head Shank Holder

- 両頭 鋼シャンクホルダー (M16 & M20 取付)
- 油穴仕様

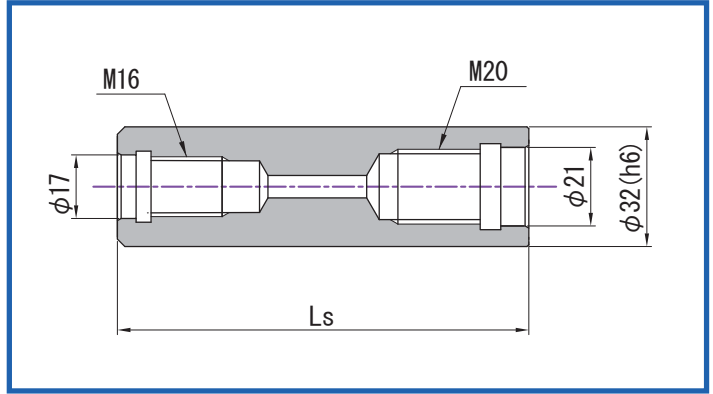

型番	在庫	寸法 (mm)	
		Ls	
M-DSH32X100-M16XM20	●	100	
M-DSH32X150-M16XM20	●	150	
M-DSH32X180-M16XM20	●	180	

M-SH

- M20 鋼シャンクホルダー (柄径φ42)
- 油穴仕様

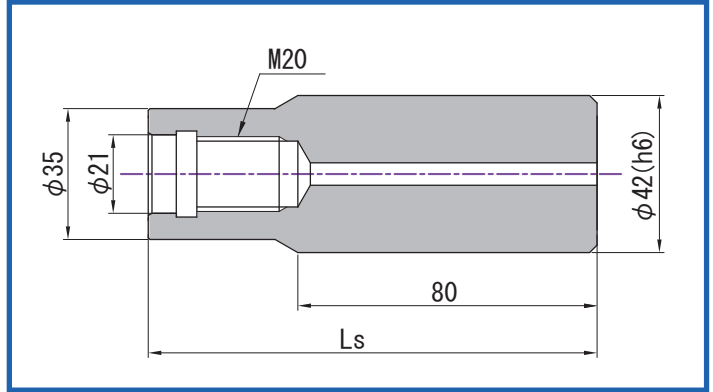

型番	在庫	寸法 (mm)	
		Ls	
M-SH42X120-M20	●	120	
M-SH42X170-M20	●	170	
M-SH42X200-M20	●	200	

M-AMX3M / 切削条件(アルミ・非鉄金属)

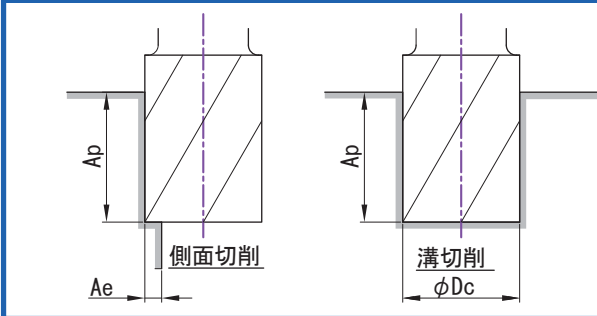

刃径 φ Dc	Ap=1.2 φ Dc Ae=0.08 φ Dc		Ap=0.5 φ Dc 以下	
	側面切削		溝切削	
	回転数 n (min ⁻¹)	送り速度 Vf (mm/min)	回転数 n (min ⁻¹)	送り速度 Vf (mm/min)
25	640	250	640	150
30	530	250	530	150
35	450	250	450	150
40	400	220	400	130
45	350	200	350	120
50	320	180	320	110

M-AMX3B / 切削条件(アルミ・非鉄金属)

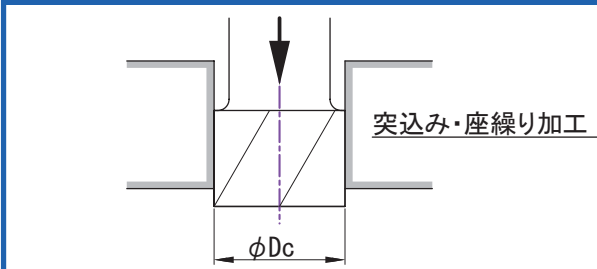

刃径 / φ Dc	突込み・座繰り加工	
	切削速度 Vc (m/min)	送り f (mm/rev)
25~50	40~60	0.07~0.12

注意事項

1. 加工中に振動、異音がする場合は、状況に応じた切削条件の変更をお願いします
2. 機械、チャック等は剛性のある精度の高いものをご使用ください
3. 工具突き出し長さは必要最小限にしてください
4. クーラントは被削材に適したものをご使用ください

〒587-0011

大阪府堺市美原区丹上530-1

TEL 072-361-4545(代) FAX 072-361-3678

 株式会社 ヤマト